

GESTRA

Steam traps and monitoring equipment

The right choice in every case





Best equipped with GESTRA steam traps

Steam traps have to work perfectly

In industry, one of steam's most important tasks is to provide thermal energy through condensation, and to heat a variety of media in heat exchangers. During this process, the steam flows through pipes and cools down more and more en route, so that condensate forms here, too.

Condensate prevents the optimum transfer of heat, but also, in particular, leads to erosion and water hammer. To enable steam systems to work reliably and efficiently, steam traps discharge any condensate that builds up, while retaining the valuable steam to the greatest possible extent. How well steam traps perform has a considerable influence on:

- the system's reliability
- availability and
- cost efficiency.

To achieve the very best results here, it needs valves that satisfy all the different requirements in every respect.

Flexible for different requirements

To heat water using steam, at times large quantities of condensate must be discharged as quickly as possible, so that drainage without banking-up can be guaranteed even if load and pressure are fluctuating.

If turbines or pipes with superheated steam are drained, only low condensate flowrates occur during operation. More condensate only forms on start-up. Here, the demand is for robustness, maintenance friendliness, durability and a regulator that closes reliably even at pressures above 200 barg.

This is what sets GESTRA steam traps apart

For steam system operators, the cost of energy production is a key driver. Durable steam traps that work without loss of steam help to keep these costs as low as possible. What's more, they ensure reliable and safe operation.

For decades now, GESTRA steam traps have epitomised optimum energy efficiency and absolute reliability. They satisfy the most demanding quality requirements, and their compact and modular design makes them impressive in the field. In addition, they are very maintenance-friendly and extremely easy and convenient to use.

Best quality for every need

At GESTRA you will find an extensive selection of functional types and versions to suit every requirement. In addition, we offer systems that enable you to reliably test and monitor your steam and condensate systems.

How do I get my optimum steam trap?

We find the optimum steam trap for you, with the best efficiency. To achieve this, what matters most is keeping an eye on the decisive factors:

1. Requirements specific to your application

- Saturated steam pipe
- Superheated steam pipe
- Steam-regulated heat exchanger
- Unregulated heat exchanger or heating coil
- Steam tracing where undercooling is required
- Turbine drainage

2. System and equipment requirements

- Pressure rating
- Type of end connection, e.g. EN flange or socket weld end
- Material of construction

3. Operating parameters

- Pressure upstream from steam trap
- Temperature upstream from steam trap
- Pressure downstream from steam trap
- Condensate flowrate
- Start-up and shut-down cycles
- Load changes

4. Additional options required

- Monitoring
- Dirt strainer
- Drain valve and manual air vent
- Manual vent valve
- Bypass

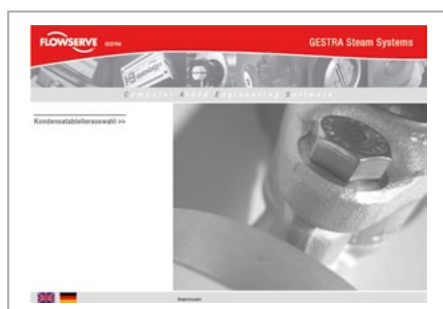

Online design software

We are happy to advise you on selecting, sizing and configuring the right steam trap for you. But first you can also use our CAESar design software. This shows you the best way to your perfect steam trap.

You can find the easy-to-use CAESar steam trap selection range on our homepage, www.gestra.com, under "Service & Support".



Steam traps with bimetallic regulator BK series

Thermostatic steam traps for removing condensate from steam or for air venting steam pipes

In steam traps with GESTRA Thermovit regulators, the opening and closing process is controlled by the interaction of bimetallic plates and a stage nozzle. It is precisely this principle that makes steam traps from the BK series highly responsive, very efficient and extremely resistant.

Use

Robust steam traps for condensate removal from heating processes with small load fluctuations.

Especially recommended for use in:

- Superheated steam pipes
- Saturated steam pipes
- Steam tracing
- Heating coils

Moreover, the BK series is ideal for use as a fast-acting air vent for steam systems.

Advantages

- Extremely good start-up performance
- No loss of steam
- Suitable for differential pressures up to 275 bar
- Able to cope with the harshest operating conditions
- Any installation position – in horizontal or vertical pipes
- Inner parts of corrosion-resistant stainless steel
- Can be serviced without removing the body from the pipe
- Metal base bushing provides the seal between the body and bimetallic regulator
- Stage nozzle for non-return valve action
- Wear-resistant

Installation example

Superheated steam pipe

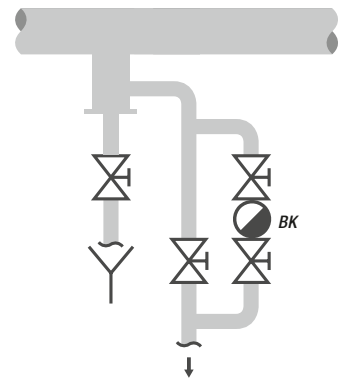

BK 15



BK 37, BK 28, BK 29



BK 37-ASME, BK 28-ASME, BK 29-ASME



BK 45, BK 46



BK 212



BK 212-ASME

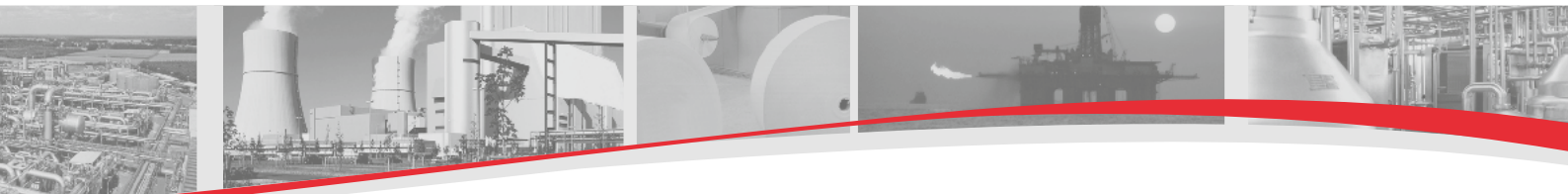

BK 45/46 in detail:

These steam traps are unaffected by frost and water hammer, resistant to corrosion and require little maintenance.

The traps regulate the flow of medium using a highly responsive GESTRA Thermovit regulator. Specially shaped bimetallic plates arranged one above the other expand as the media temperature rises, moving the stage nozzle. The flow orifice closes. In the cold state, the regulator is fully open. That is why steam traps from the BK series boast an excellent start-up performance.

Key data

Robust GESTRA Thermovit regulator for removing condensate from heating processes with small load fluctuations.

- DN 15 – 25 (NPS ½" – 1")
- PN 40/Cl 300
- Max. differential pressure: 22 or 32 bar
- Easy to install RHOMBUSline body with recessed body gasket and metal base bushing
- Integrated non-return valve action
- Dirt strainer with large surface area (Y-strainer)

Options

- Integrated steam trap monitoring for loss of steam and banking-up of condensate
- Blow-down valve

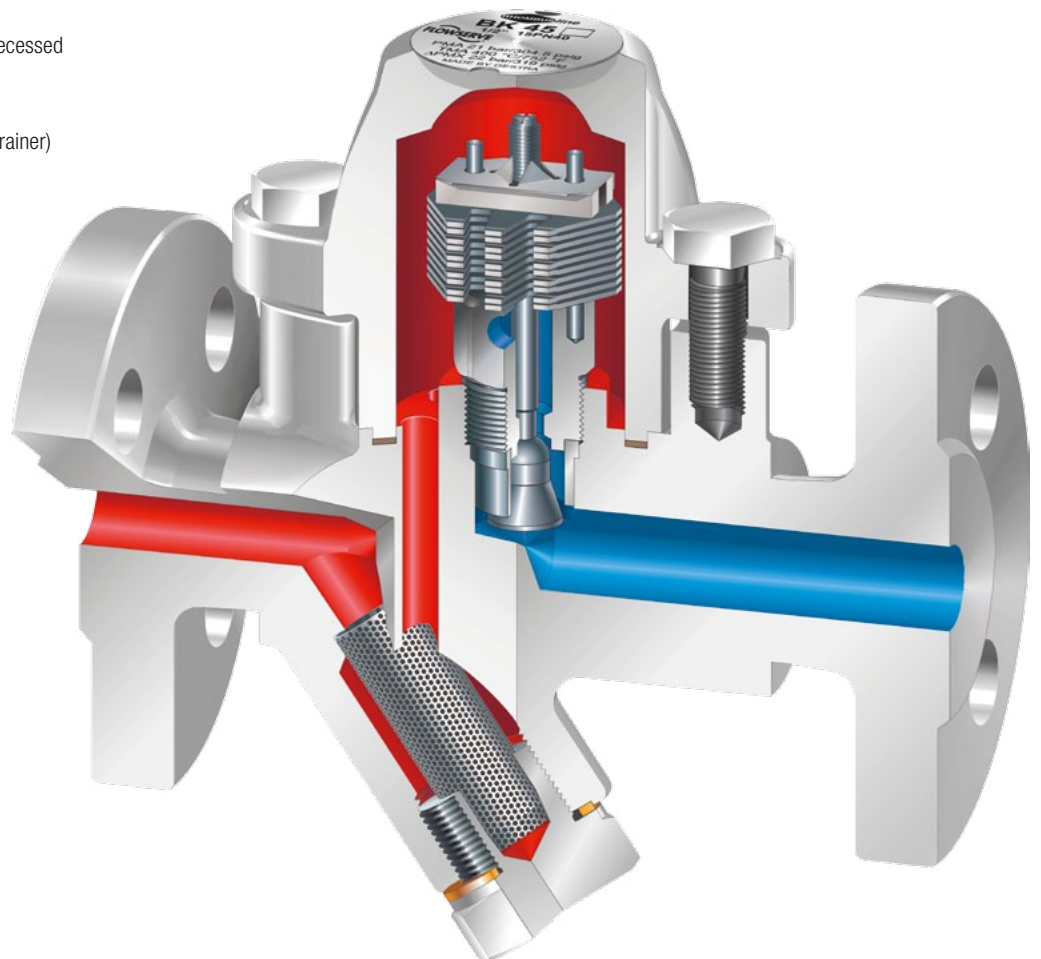



Steam traps with membrane regulator MK series

Thermostatic steam traps for removing condensate from steam or for venting steam pipes

A distinguishing feature of the MK series is the outstanding responsiveness of the membrane regulator. It is especially suitable for heat exchangers whose operation is adversely affected even by minimal banking-up of condensate.

Use

Highly responsive steam trap for draining heating processes.

Especially recommended for use in:

- Saturated steam pipes
- Steam tracing
- Heating coils
- Air heaters
- Steam roller presses/iron presses
- Tyre presses

Moreover, the MK series is ideal for use as an extremely fast-acting air vent for steam systems.

Advantages

- Extremely fast response by the GESTRA thermostatic capsule
- Flat seat or tandem seat
- No loss of steam
- Function uninfluenced by upstream or back pressure
- Any installation position – in horizontal or vertical pipes
- Large hot water flowrates even at low differential pressure
- Inner parts of corrosion-resistant stainless steel
- Wear-resistant membrane film of Hastelloy
- Three different types of membrane capsules for different areas of use
- Long service life

Installation example

Tyre press

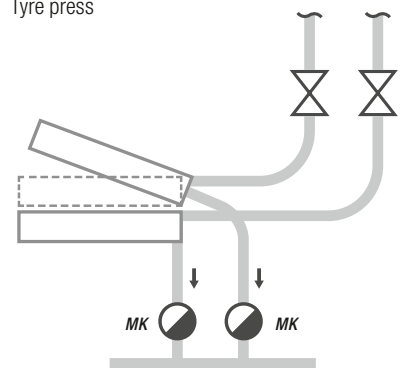

MK 45/45A in detail:

MK 45-1 with tandem seat guarantees maximum tightness and durability.

These traps work with the extremely responsive GESTRA thermostatic capsule. This enables them to perform drainage tasks in applications with very stringent control quality requirements. Condensate is discharged reliably and almost immediately.

Key data

- DN 15 – 25 (NSP ½" – 1")
- PN 40/Cl 300
- Max. differential pressure: 32 bar
- Easy to install RHOMBUS*line* body with recessed body gasket and metal base bushing
- Integrated non-return valve action
- Dirt strainer with large surface area (Y-strainer)

Options

- Tandem seat with double, stepped seat for maximum, long-lasting tightness and small to medium condensate flowrates
- Flat, single seat for larger condensate flowrates
- Integrated steam trap monitoring for loss of steam and banking-up of condensate
- Blow-down valve
- Stainless steel version (MK 45A)

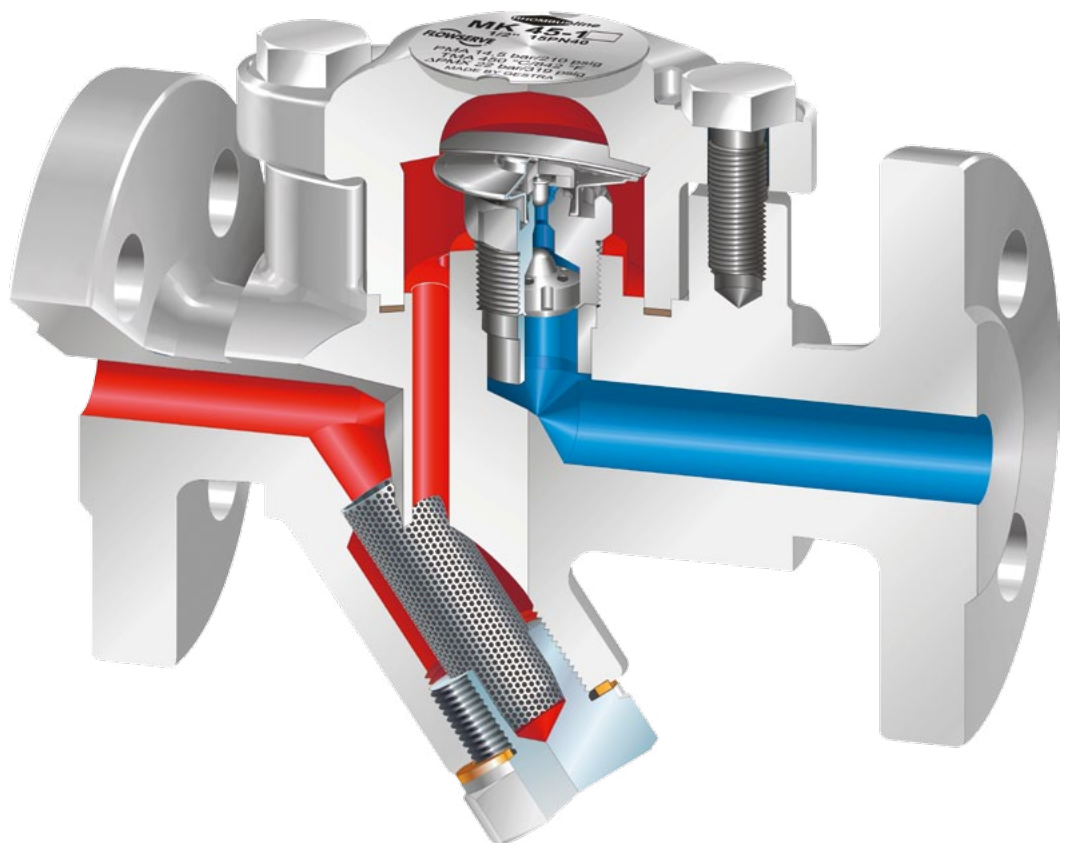



Ball float steam traps UNA series

Steam traps with ball float for removing condensate from steam, cold condensate or distillates without banking-up

The traps with the tried and tested rolling ball seal work with exceptionally low friction and therefore have very low actuating forces. They are durable and guarantee maximum tightness.

Use

Versatile steam trap for virtually all requirements.

Especially recommended for the drainage of:

- Steam-regulated heat exchangers
- Systems with a large condensate flowrate
- Steam headers
- Steam driers, cyclone separators
- Systems with very low operating pressures
- Systems with very small differential pressures
- Systems with extremely variable operating conditions
- Vacuum systems
- Float traps with integral air vents can be used as air traps, gas traps and liquid drainers
- Drying cylinders

The series is also ideal for use as a discharge regulator for flash tanks and feedwater tanks.

Advantages

- Reliable function regardless of back pressure and condensate temperature
- No loss of steam due to the formation of a water seal
- Maximum tightness and durability as well as excellent control characteristics, as the sealing unit of the regulator has a rolling ball or segmented ball
- Immediate response level control without automatic venting – Simplex version
- With automatic, fast-acting venting for steam systems – Duplex version
- Especially insensitive to dirt
- Inner parts of corrosion-resistant stainless steel
- Fully operational even when back pressure is nearly 100% of upstream pressure
- Can be serviced without removing the body

Installation example

Brewing pan

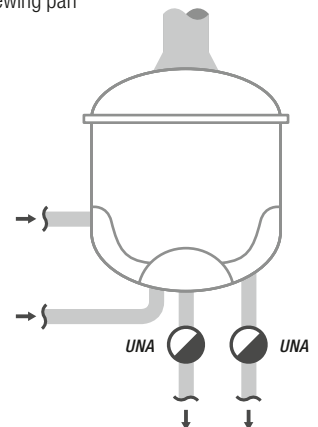

UNA 14



UNA 45, 46 with electrode and manual vent valve



UNA 27



UNA 38



UNA 39



UNA Special

UNA 45/46 in detail:

GESTRA UNA 4 ball float steam traps cannot fail to impress, with their simple, modular design that makes them perfectly flexible in use.

The modular design means that the steam trap's direction of flow can be varied. With a total of 33 different options for installation in the pipe (11 types of connection for each direction of flow – vertical, horizontal to the left and horizontal to the right), these traps fit every pipe. The materials and design of the forged body conform to EN and ASME standards.

Key data

- DN 15 – 65 (NPS ½" – 2½")
- PN 40/CI 300
- Max. differential pressure: 32 bar
- Rolling ball regulator with various pressure capabilities A02 – A032 (DN 15-65)
- MAX regulator (DN 40 – 65) for large condensate flowrates over 15,000 kg/h (hot condensate)

Options

- Direction of flow vertical, horizontal to the left or horizontal to the right
- Inner bypass, adjustable from outside
- Sightglass (UNA 45) PN 16/CI 150
- Connection for monitoring sensor
- Cover with monitoring sensor (UNA 45) PN 40/CI 300
- Manual lifting lever
- Dirt strainer
- Stainless steel version (UNA 46A)

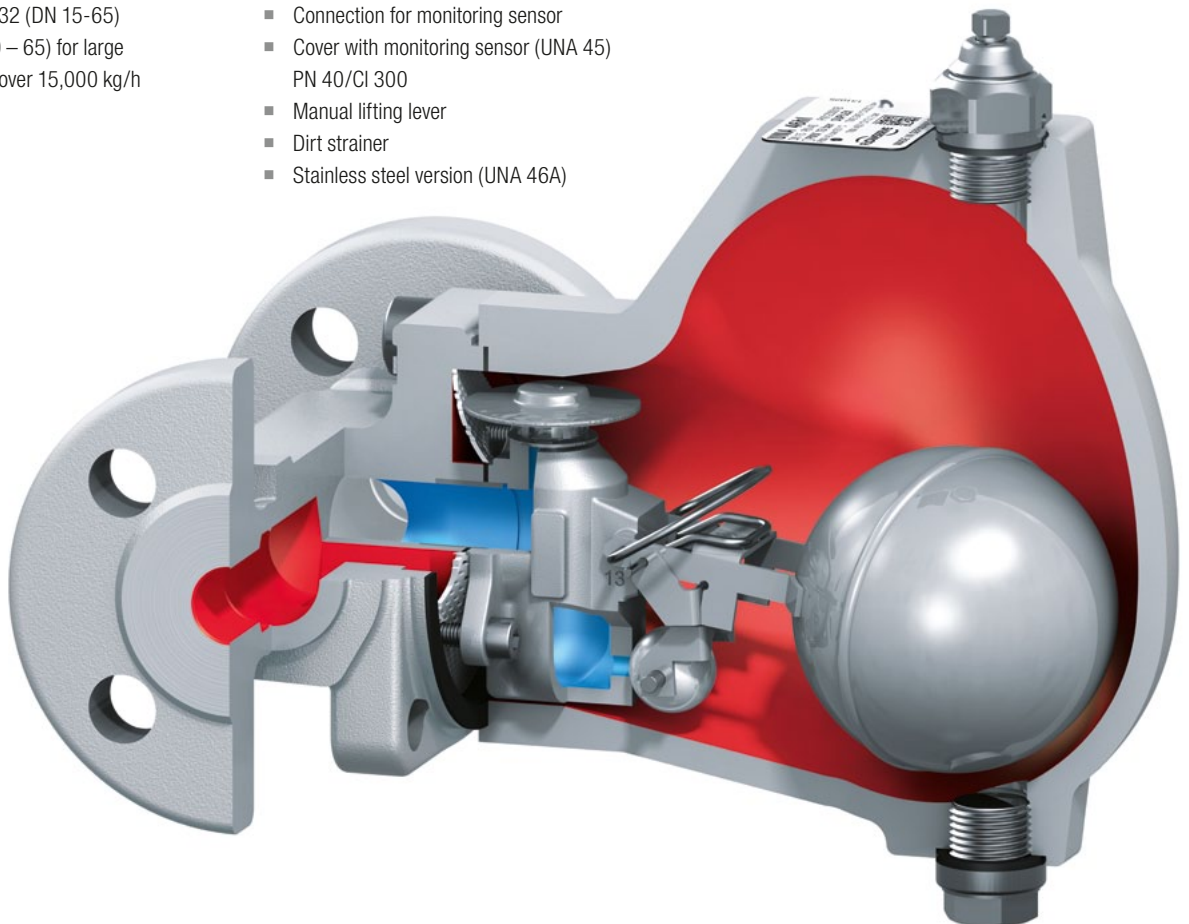



Thermodynamic steam traps DK series

Steam traps for draining steam systems

These steam traps work on the basis of a simple thermodynamic principle. Incoming condensate lifts the disc of the regulator to the open position, while steam causes it to close immediately. The traps in the DK series are correspondingly simple in construction, feature a small, compact body and are low in cost.

Use

Compact steam trap for draining heating processes with small load fluctuations.

Especially recommended for use in:

- Saturated steam pipes
- Superheated steam pipes
- Steam tracing
- Air heaters

Advantages

- Compact, highly responsive regulator
- Small number of functional parts
- Drainage with practically no banking-up
- Any installation position – in horizontal or vertical pipes
- Permitted back pressure up to 80% of upstream pressure
- Available as an easy-to-install RHOMBUSline body with replaceable regulator, or as a compact version
- Inner parts of corrosion-resistant stainless steel

Installation example

Steam pipe

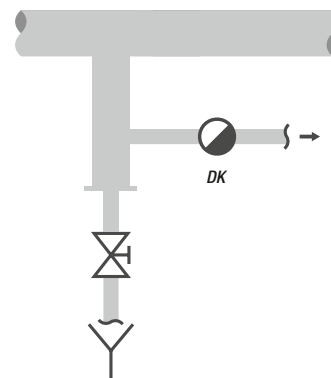

DK 47



DK 57



DK 45

DK 47 in detail:

Compact, resistant and low-priced steam traps of stainless steel

The DK 47 thermodynamic steam trap is made of stainless steel and has an integrated dirt strainer. It has an especially compact design with a threaded cover. These traps boast an impressive price/performance ratio.

Key data

- DN 10 – 25 (NPS 3/8" – 1")
- PN 63
- Max. differential pressure: 42 bar
- Dirt strainer with large surface area (Y-strainer)
- Screwed end

Options

- Low capacity version for small condensate flowrates
- High capacity version for large condensate flowrates
- Blow-down valve

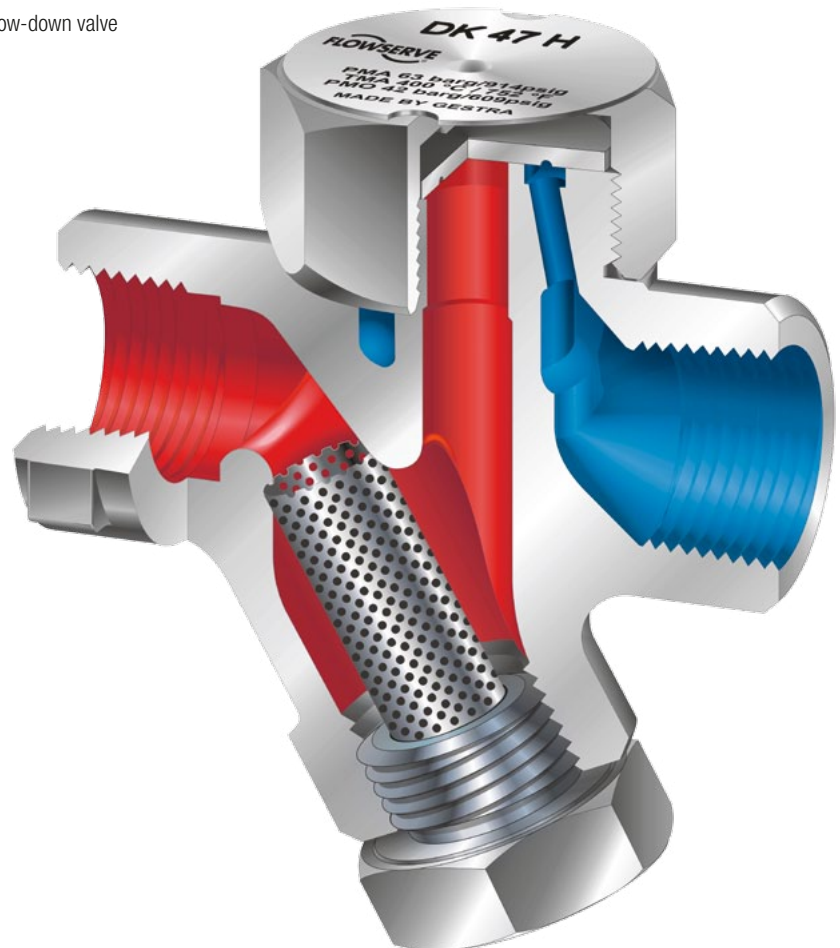



Steam traps with membrane regulator SMK series

Thermostatic steam traps with minimum stagnant area for sterile and aseptic applications

For CIP (clean-in-place) and SIP (steam-in-place) processes, recognition of the phase, i. e. steam or water, and an adequate steam trap reaction time are crucial factors. The STERLine membrane regulators used in the SMK series react especially quickly to a change in temperature or a change in phase, due to their design, smaller surface area and low weight.

Use

Extremely responsive steam trap – especially suitable for draining in:

- The pharmaceutical industry
- Pure steam and ultrapure steam applications
- Clean-in-process (CIP)
- Steam-in-place (SIP) processes

Advantages

- Fast and precise STERLine thermostatic capsule
- Achieves an almost constant system temperature
- Minimum stagnant area
- All parts in contact with medium are of high-quality stainless steel
- Design principle allows installation with few welded joints
- Functional unit can be replaced quickly and safely
- Optional short design with clamp connection

Installation example

Sterile tank

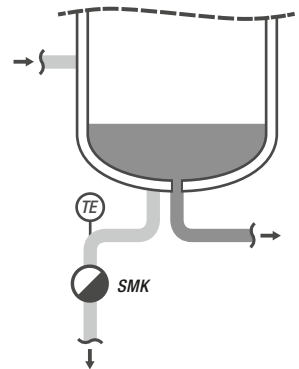

SMK 22



SMK 22-51



SMK 22-81, SMK 22-82

SMK 22 in detail:

Fast acting regulator with minimum crevice body design for minimum stagnant area.

These traps work with the extremely responsive GESTRA *STERIline* thermostatic capsule. This ensures the steam traps can also perform drainage tasks with stringent requirements for high-quality control and a clean process. Condensate is discharged reliably and almost immediately.

Key data

- DN 10 – 25 (NPS 3/8" – 1")
- PN 10
- Max. differential pressure: 6 bar
- Surface roughness: $\leq 0.8 \mu\text{m}$
- GESTRA *STERIline* thermostatic capsule

Options

- Surface roughness $\leq 0.4 \mu\text{m}$
- Various *STERIline* thermostatic capsules for small and large condensate flowrates
- Different end connections available, including clamp version for weld-free assembly

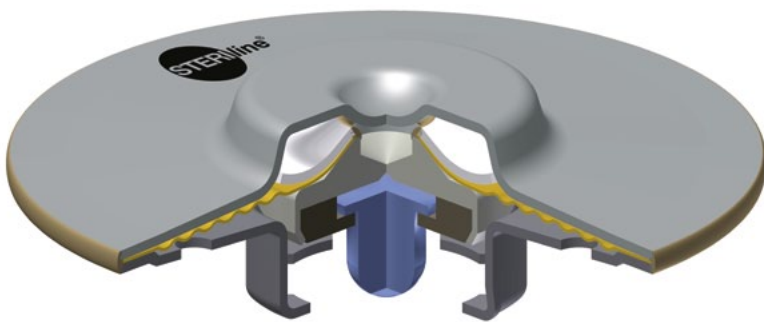

STERIline 1 thermostatic capsule for small condensate flowrates

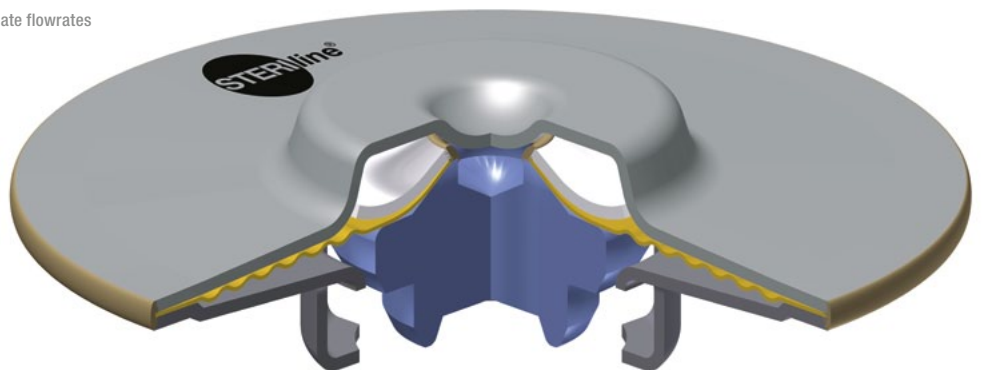

STERIline 2 thermostatic capsule for large condensate flowrates



Pumping trap **UNA 25-PK**

Pumping trap **UNA 25-PS**

Valves that discharge and lift condensate

Ball-float steam traps with pump function – UNA 25-PK:

These units function primarily as steam traps. The integrated, automated pump function ensures that condensate is discharged even under reduced steam pressure or high back pressure. The condensate is then pumped out of the body with the aid of motive steam.

Pump trap with ball float – UNA 25-PS:

The automated pump function ensures that the return of condensate is always based on demand. The condensate is pumped out of the body with the aid of motive steam.

Use

UNA 25-PK:

- Regulated heat exchangers, special plate-type heat exchangers with major load fluctuations during operation
- Drainage of vacuum systems
- Also suitable for returning condensate

UNA 25-PS:

- For returning condensate, e.g. as an alternative to pump-driven return
- Drainage of vacuum systems

Advantages

- Integrated non-return valve in the inlet and outlet area
- Body with straight through design
- Small size
- Standard flange length
- Float-actuated, compact switchover unit for controlling booster steam and venting
- Optimised performance with versions for 6 bar or 13 bar
- Inner parts of corrosion-resistant stainless steel
- Compact regulator unit

Installation example

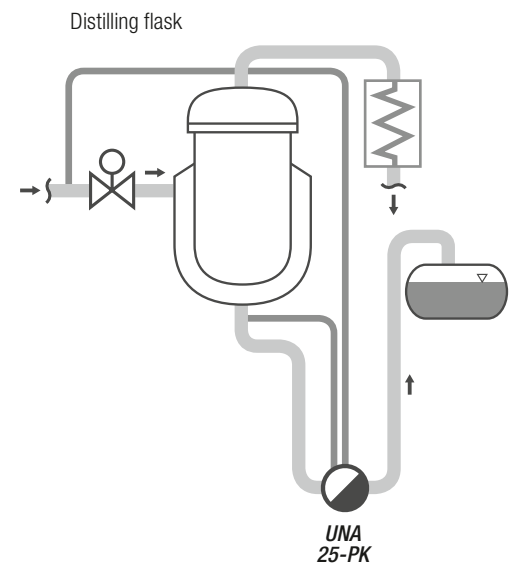

UNA 25-PK, UNA 25-PS



UNA 25-PK, UNA 25-PS

UNA 25-PK in detail:

The use of compact UNA 25-PK units guarantees drainage without banking-up, and a leakproof seal in all operating conditions

In addition to the tried-and-tested rolling ball regulator, a mechanism is incorporated that independently conveys higher pressure steam into the body when the upstream pressure is low. With this motive steam, the condensate is actively fed into the condensate system. When the pressure in the heat exchanger is sufficiently high, the rolling ball regulator works like a conventional ball-float steam trap.

Key data

- DN 40 (NPS 1½")
- PN 40/Cl 150
- Max. differential pressure: 6 or 13 bar
- Compact regulator unit, contains control block and switchover unit
- Modular control block
- Separate, wear-resistant connections for motive steam and venting
- Orifice with rolling ball
- Integrated non-return valve in inlet and outlet area

Options

- Different versions for 6 bar or 13 bar operating pressure
- EN flange, ASME flange or screwed end connection

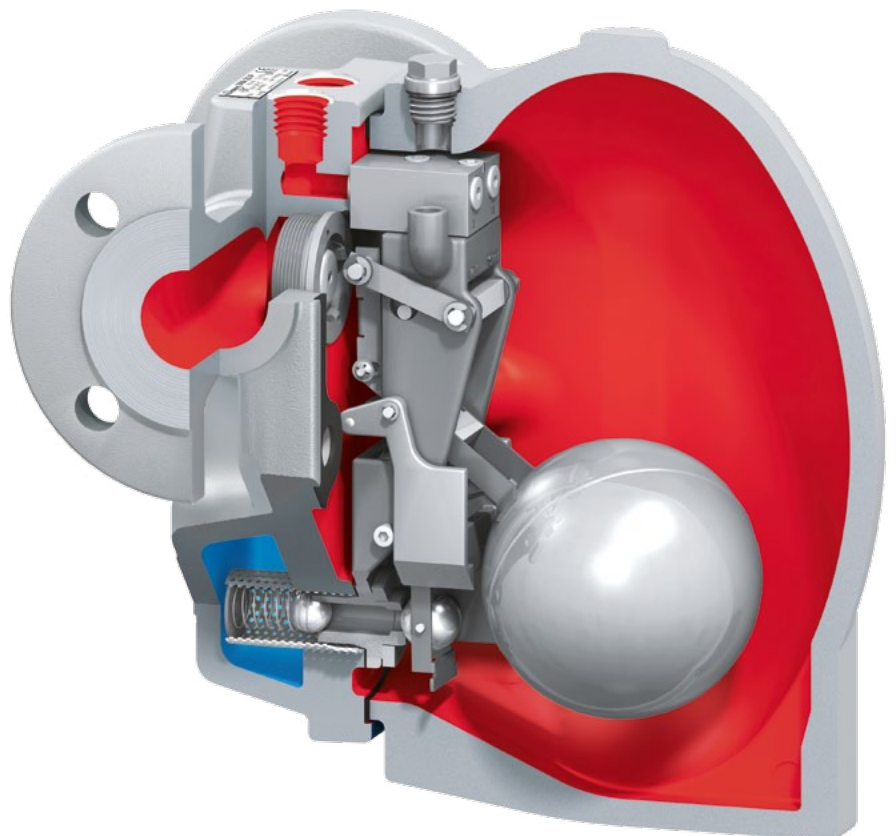



Drainage modules of the QuickEM series

Preassembled modules for quick and easy installation

GESTRA QuickEM drainage modules are units with carefully arranged pipework, consisting of a steam trap, sightglass, check valve, stop valves and bypass pipe, plus all the necessary pipes, flanges, gaskets and fasteners.

GESTRA QuickEM-Control drainage modules are used for steam trap monitoring and are equipped with an electrode either in the steam trap itself or in a test chamber.

Use

The preassembled modules are used for draining e.g.:

- Steam pipes
- Steam headers
- Heat exchangers

Advantages

- Preassembled steam trap module with the recommended additional valves
- Saves time on installation
- Keeps installation errors to a minimum
- Also available without bypass
- QuickEM-Control with integrated monitoring electrode
- Standardised lengths
- For horizontal or vertical installation
- Also available in stainless steel

Installation example

Saturated steam pipe

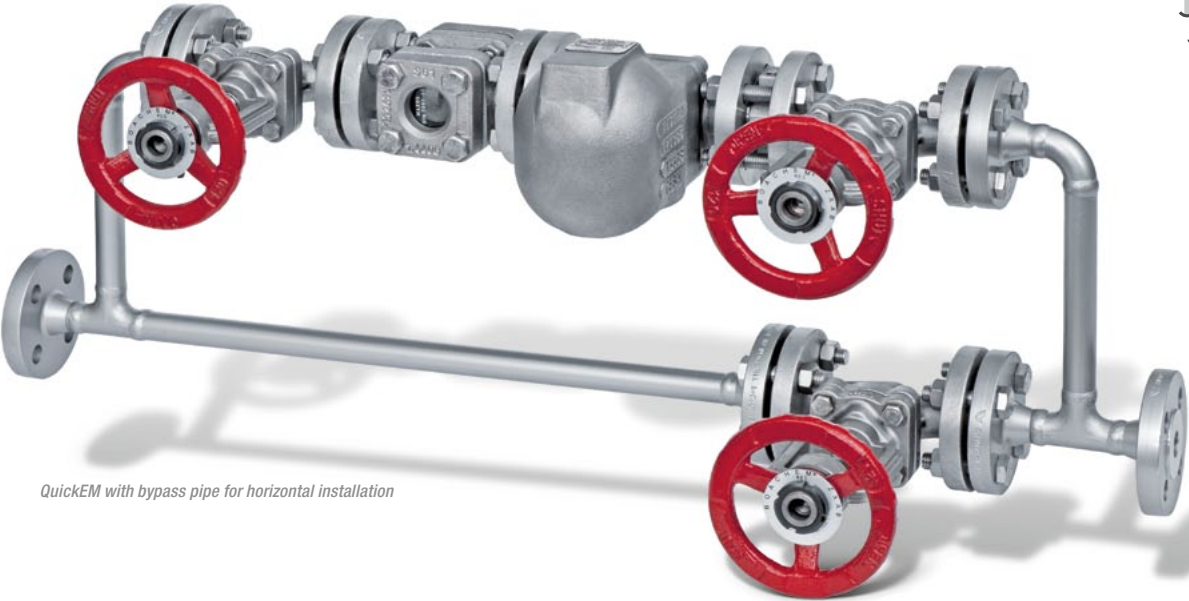
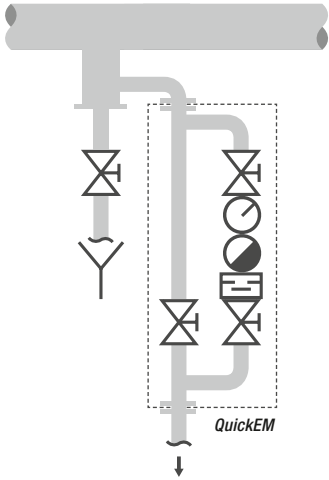

QuickEM with bypass pipe for horizontal installation

QuickEM with UNA 16A ball-float steam trap, Vaposcope and bypass in detail:

Drainage module with optimum, dirt-protected positioning of the steam trap to ensure ideal operation.

This type of QuickEM is a preassembled drainage module in stainless steel, complete with steam trap, monitoring function and maintenance-friendly bypass. It features a UNA 16A ball-float steam trap, which works with extremely low friction and therefore requires very low actuating forces. It also promises outstanding durability.

Key data

- DN 15 – 25 (NPS ½" – 1")
- PN 40
- Max. differential pressure: 22 bar
- Stainless steel version

Options

- Choice of BK, MK or UNA steam trap
- Versions for horizontal or vertical installation
- Without bypass pipe
- Monitoring electrode
- Carbon steel or stainless steel version
- Also available in larger nominal sizes – DN 40 and DN 50

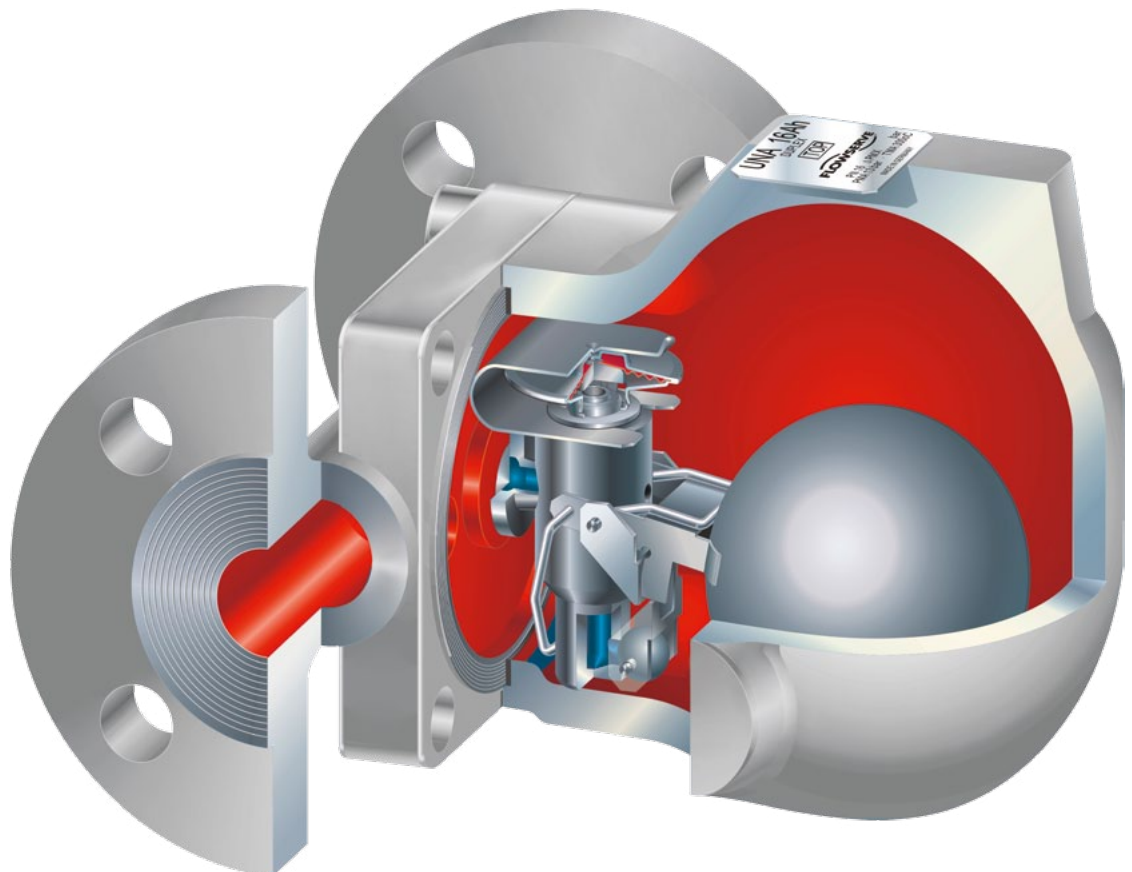

UNA 16Ah ball-float steam trap



Compact steam trap with universal connection

Steam traps for universal connectors

Compact, maintenance-free steam traps of stainless steel for connection to universal pipeline connectors. These steam traps can be secured with just two screws. Installation and removal is therefore extremely quick and simple.

For connection to universal connectors, we offer: The types of connector are:

- Steam traps with membrane regulator – MK 36A-71/-72
- Bimetallic steam traps – BK 36A-7
- Thermodynamic steam traps – DK 36A-7
- Inverted bucket steam traps – IB 16A-7
- Simple – UC 36
- With dirt strainer (Y-strainer) – UCY 36
- With integrated stop valves, test and drainage valve – TS 36

Use

Suitable for discharging small to medium condensate flowrates.

Ideal for draining:

- Pipes
- Steam tracing

Advantages

- Very maintenance-friendly, as the connector remains in the pipe even during replacement
- Any installation position – in horizontal or vertical pipes
- Integrated spiral wound gaskets on the steam trap
- Fast assembly time, secured with just 2 screws
- Low maintenance costs
- Body and inner parts of corrosion-resistant stainless steel

Installation example

Steam pipe

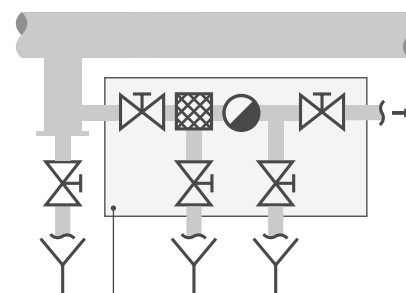

TS 36 and steam trap



BK 36A-7



IB 16A-7



UC 36



UCY 36



TS 36

TS 36 with BK 36A-7 add-on in detail:

A winning combination: compact, robust steam trap with no loss of steam, together with all stop valves and test and drainage function

The TrapStation TS 36 encompasses the universal connector, two stop valves – which are accessibly positioned and clearly colour-coded to ensure easy and safe operation – a drainage valve with dirt strainer for removing corrosion products, and a test valve. A straightforward function test can be performed in no time, and the steam trap can be easily cleaned. This considerably extends its service life.

Also included is a BK 36A-7 thermostatic bimetallic steam trap with corrosion-resistant, water hammer-resistant Thermovit regulator for drainage with virtually no banking-up, and automatic air venting.

Key data

- DN 15 – 25 (NPS ½" – 1")
- Cl 300
- Max. differential pressure: 32 bar

Options

- Screwed or socket weld end connection
- Direction of flow left to right or right to left
- Optionally available without test and blow-down valve
- Accessory: Special extraction tool for replacing the stuffing box

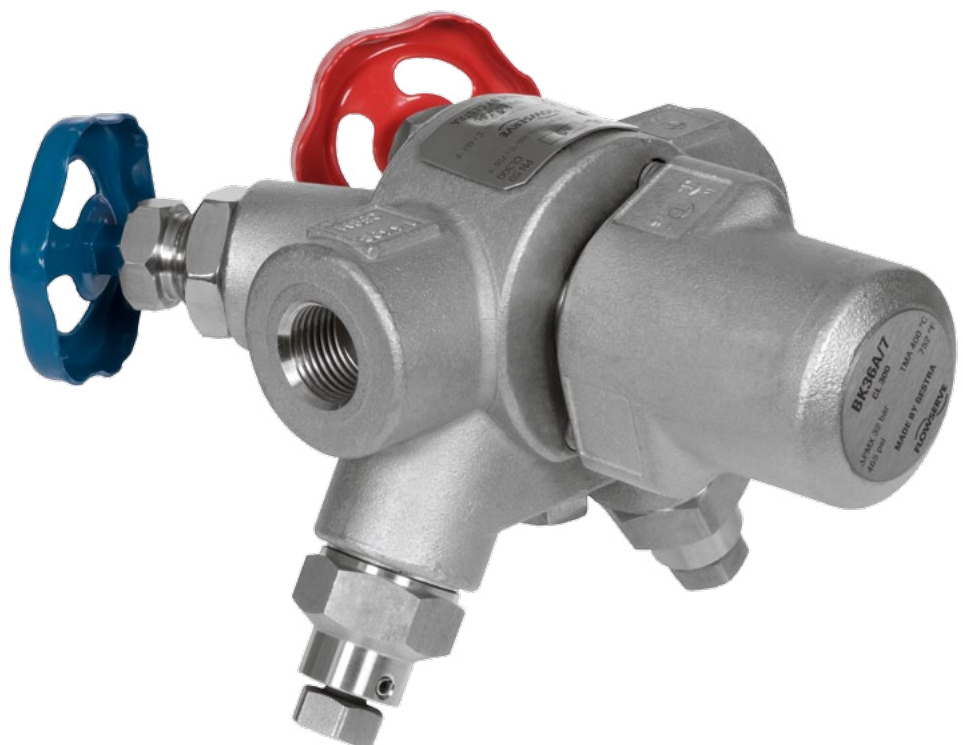



Integrated steam trap monitoring VK, NRG, VKE

Visual or electronic – a reliable watchdog for every steam trap

Unwanted banking-up of condensate leads to an inadequate exchange of heat energy and the possibility of water hammer damage. A loss of steam costs energy and therefore constitutes a major financial loss. Moreover, both of these can adversely affect system safety. Therefore, monitoring steam traps for the banking-up of condensate and loss of steam always makes sense. Sightglasses – GESTRA Vaposcopes – or monitoring electrodes are a fixed part of the equipment.

VK Vaposcopes are sightglasses that allow you to see flow processes in pipes. When they are installed upstream from a steam trap, you can easily see whether the steam trap is suffering a banking-up of condensate or loss of steam.

- The special design of the GESTRA Vaposcope makes any loss of steam clearly visible

NRG electrodes measure conductivity or temperature and therefore recognise, either in an upstream VKE test chamber or in the steam trap itself, the presence of an abnormal operating state. The electrode signal is processed by a single or multi-channel diagnostic tester.

- The diagnostic tester has different operating modes to ensure intelligent diagnosis
- Conductivity signal for clear, immediate detection of banked-up condensate
- Conductivity electrodes with temperature sensor for universal monitoring

Installation example

Heat exchanger

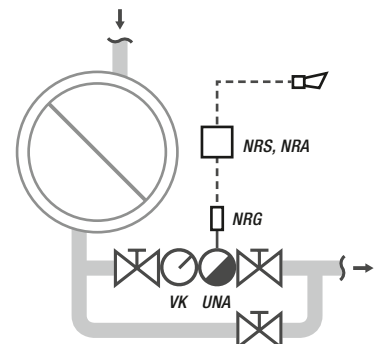

VK 14



VKE 16-1 with NRG 16-19



VK 16



NRG 16-19

NRG 16-27



NRA 1-3

Vaposcope VK 16 in detail:

Extremely clear and simple visual function test

If the steam trap is functioning perfectly, the tip of the Vaposcope's deflector is immersed slightly in the water seal, which is produced in the sightglass due to the siphon effect. If a loss of steam occurs, the amount of water in the seal decreases and the tip of the deflector is no longer immersed. If condensate is banking up, the sightglass is filled completely.

Key data

- DN 15 – 50 (NPS ½" – 1")
- Body with straight through design and two opposing borosilicate sightglasses for improved viewing
- With mica disc as standard for higher pH values
- Valve with no moving parts
- Maintenance-free

Options

- Flange, screwed or socket weld end connections

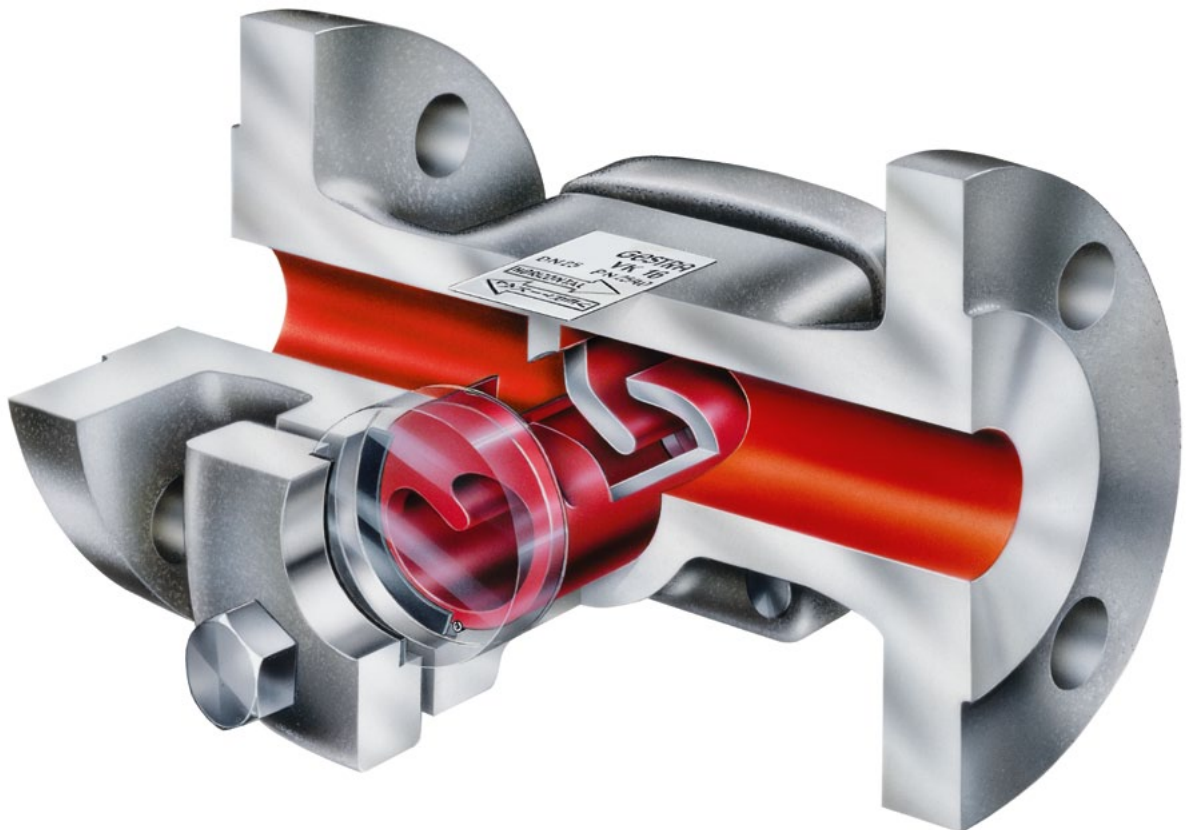



Steam trap testing equipment **VKP 10, VKP 40plus, VKP 40plus Ex**

Prevent steam leakage and banked-up condensate with state-of-the-art technology

Steam traps are subject to wear. This could lead to loss of steam or banking-up of condensate. Experience shows that the failure rate of faulty steam traps is as much as 25%. This failure rate can be slashed to less than 5% with annual inspections and the necessary maintenance.

Use

Steam traps of any manufacturer can be inspected by ultrasonic measurement during ongoing operation. The measured ultrasonic spectrum is shown on a display unit as needle deflection on a scale, or as a curve on a graph, depending on the testing system used.

Advantages

- Extremely mobile test equipment for high flexibility
- Simple and fast testing of all steam traps from any manufacturer
- Unambiguous test results
- Data collector for ease of use
- VKP 40plus Ex approved for use in potentially explosive atmospheres



VKP 10

Data collector VKP 40plus

Measuring transducer with Com-Box

TRAPtest VKP 40plus Ex in detail:

A self-explanatory menu navigation provides ease of use and clarity of results

With the GESTRA TRAPtest VKP 40plus Ex testing, recording and evaluation system, steam traps of any manufacturer can be checked for loss of steam and banking up of condensate – including those in potentially explosive atmospheres. The associated TRAPtest software enables simple and extensive analysis of test results and a clear presentation of potential savings.

Key data

- Automatic assessment of tested steam traps
- Graphic presentation of readings
- Integrated temperature measurement to detect banked-up condensate
- Large choice of languages, can be individually extended and adapted
- Interface with MS Excel®
- Clear repair orders printed
- Simple financial analysis
- Intuitive operation via touchscreen
- Choice of spontaneous or documented measurement
- Intrinsically safe to Ex II 2G Ex ib IIC T4 Gb
- Degree of protection IP 65

Options

- VKP 40plus for use in non-explosive atmospheres

Monitoring pays off

Cost of steam generation: 30 euros/tonne
 Operating hours: 8,000 hours/year
 Loss of steam per steam trap: 3 kg/hour

Faulty steam traps	Loss per year
1	3,8 t CO ₂ => 720 EUR
10	38,4 t CO ₂ => 7,200 EUR
50	192 t CO ₂ => 36,000 EUR
200	768 t CO ₂ => 144,000 EUR



VKP 40plus Ex



Valve for reliable discharge of condensate on start-up Automatic drainage valve AK 45

Replaces hand-operated or separately operated air venting valves on start-up

The AK 45 rapidly and automatically discharges air and condensate from steam systems on start-up and drains residual fluid when the system is shut-down. It is also used for frost protection. The integrated spring enables the AK 45 to open without pressure. The valve closes as soon as the operating pressure increases to the closing pressure set for the AK 45. If the operating pressure falls below closing pressure once more, the AK 45 is opened by spring force and drains residual fluid, preventing the formation of a vacuum.

Use

Suitable for all steam and condensate systems:

- For drainage during start-up and shut-down
- For frost protection

Advantages

- Automatic system drainage to prevent water hammer and frost damage
- Inner parts of corrosion-resistant stainless steel
- Hand-purging knob for removing dirt

Installation example

Steam header

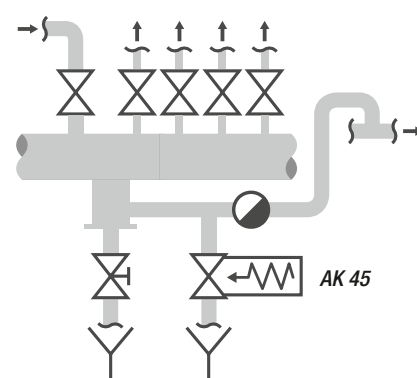

AK 45



AK 45

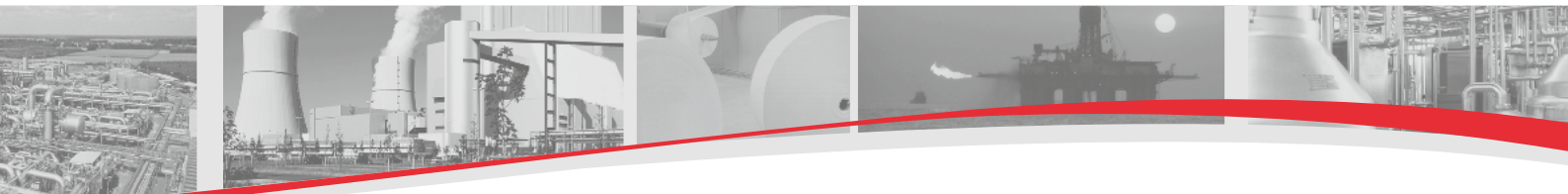

Key data

- DN 15 – 25 (NPS ½" – 1")
- PN 40
- Closing pressure: 0.8 bar
- Dirt strainer with large surface area (Y-strainer)
- Hand-purging knob for purging condensate
- Easy to install RHOMBUSline body with recessed body gasket and metal base bushing

Options

- Closing pressure 0.5 bar, 1.5 bar or 2.0 bar

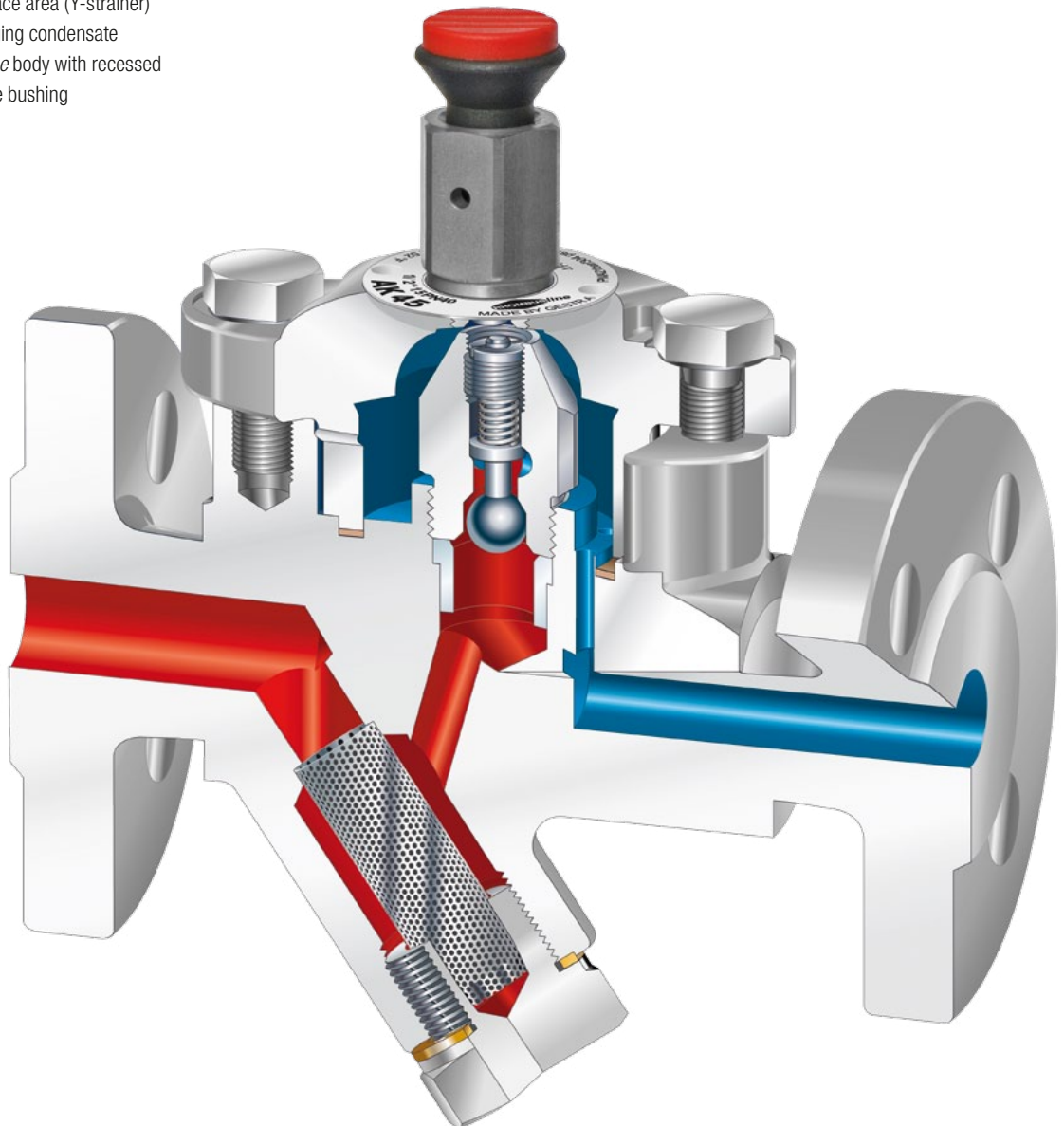



Steam traps with thermostatic pilot control for large condensate flowrates

Duo Super steam traps TK 23, TK 24

Discharge rate: up to 140 tonnes of condensate an hour

TK 23 and TK 24 Duo Super steam traps are highly responsive steam traps with pilot control provided by GESTRA thermostatic capsules. They are used for discharging large and continuous condensate flowrates.

Use

These steam traps are suitable for the automatic drainage of heat exchangers.

They are especially recommended for:

- Evaporators
- Heat exchangers with a high output
- Large boilers
- Brewing kettles
- Chemical and petrochemical processes

Key data

- DN 50 – 100 (NPS 2"– 4")
- PN 16/25
- Max. differential pressure: 5 bar with OH2 thermostatic capsules and 10 or 14 bar with 5H2 thermostatic capsules

Advantages

- GESTRA thermostatic capsules are highly responsive – also suitable for especially low operating pressures, even below 1 barg
- Extremely good air venting performance
- Externally adjustable flowrate and response threshold, enabling optimum adaptation to current operating conditions
- Compact body with straight through design and standard face-to-face dimension
- Compact regulator unit with membrane capsule damping plate and threaded main seat

Installation example

Large boiler

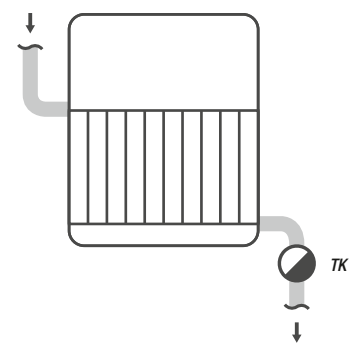

TK 23

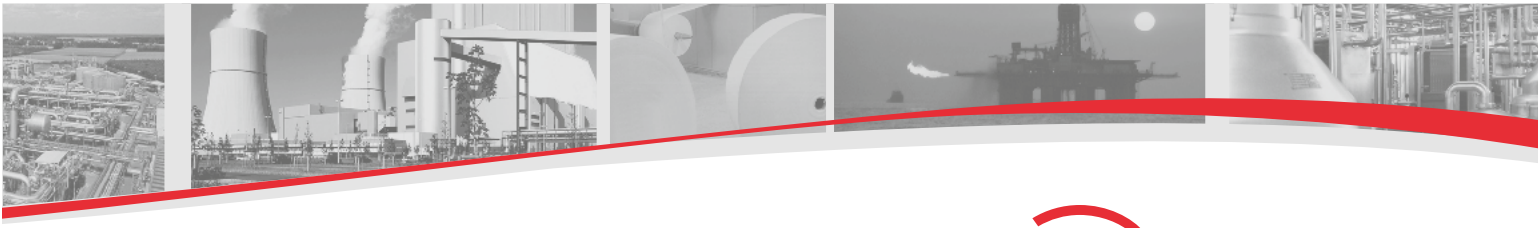

Robust steam trap for discharging larger condensate flowrates

Super steam traps GK 11, GK 21

Discharge rate: up to 380 tons of condensate an hour

GK 11 and GK 21 Super steam traps are manually controllable steam traps with integral sightglass. GK 11 and GK 21 steam traps are used for discharging large, continuous condensate flowrates at low pressure.

Use

These traps are suitable for the effective, manual drainage of evaporators, and are chiefly employed in:

- Sugar refineries
- The aluminium industry

Key data

- DN 50 – 150 (NPS 2"–6")
- PN 16
- Max. differential pressure: 6 bar

Advantages

- Stage nozzle for low-wear operation
- Seat with slotted drum for optimising step-by-step depressurisation
- Handwheel with stroke indicator for easy adjustment in line with current operating conditions
- Visual monitoring by large Vaposcope integrated in the body, ensuring drainage without banking-up or loss of steam
- Compact body with straight through design
- Compact regulator unit

Installation example

Falling film evaporator

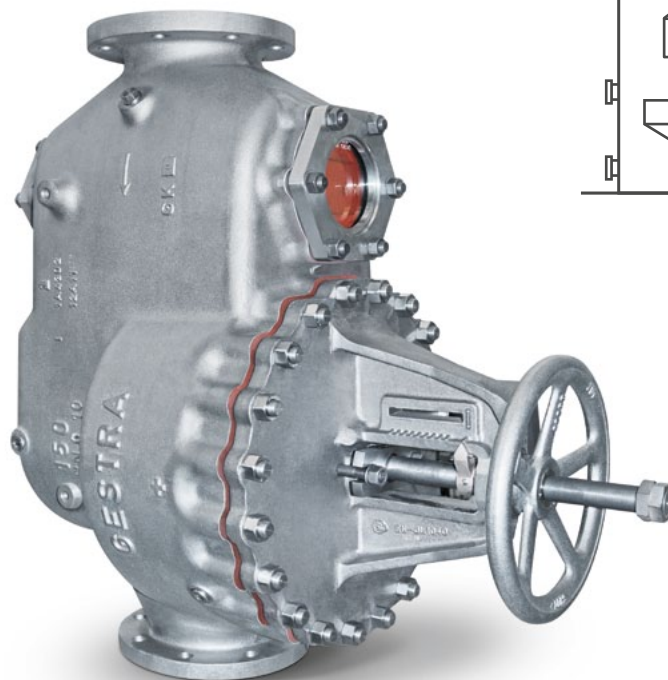
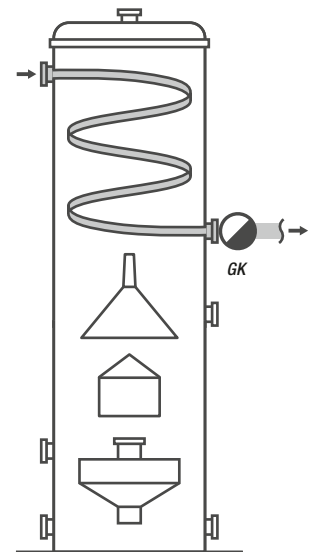

**All GESTRA
steam traps
at a glance**



GESTRA AG

Münchener Strasse 77, D-28215 Bremen

Postfach 10 54 60, D-28054 Bremen

Phone +49 (0) 421-35 03-0

Fax +49 (0) 421-35 03-393

e-mail gestra.ag@flowserve.com

Internet www.gestra.de



With Energy into the Future